

## Review of Wireless Power Transfer Techniques for Electrical Vehicles

Hasan Y. Mohammed<sup>1</sup>, Ahmed J. Ali<sup>2</sup> and Rakan Khalil Antar<sup>3</sup>

<sup>1,2,3</sup>Department of Electrical Power Technology Engineering, Technical Engineering College, Northern Technical University, Mosul, Iraq

[hasan.yousef@ntu.edu.iq](mailto:hasan.yousef@ntu.edu.iq); [ahmed.j.ali@ntu.edu.iq](mailto:ahmed.j.ali@ntu.edu.iq); [rakan.antar@ntu.edu.iq](mailto:rakan.antar@ntu.edu.iq)

Received: January 02, 2023

Revised: February 15, 2023

Accepted: March 02, 2023

### Abstract:

Wireless Power Transfer (WPT) is a technology of transmitting electric, magnetic, optical, or microwave power without the use of physical connections. This technology is used to charge electric vehicles and other applications. It has several advantages over conductive charging method in terms of automation, safety in harsh environments, as well as reliability during environmental disasters. However, this technology faces challenges such as complex design, high cost, and sensitivity to misalignment and safety conditions for people. These challenges are associated with receiver and transmitter coils. This paper provides an overview of transmitter coil types, magnetic materials used, types of shields to provide safety for people, various pads structures, as well as the types of methods used to charge electric vehicles and electronic compensation circuits. This paper will be a reference for researchers and those interested in wireless power transfer to check these factors.

**Keywords:** Pads, Ferrite, Compensation Circuits, Shielding, Coupling Factor, WPT.

## 1 Introduction

The transportation sector is currently one of the main consumers of fossil fuels, making it the largest contributor to greenhouse gases. There is an urgent need to develop electric vehicle technologies to reduce the increasing dependence on fossil fuels. Electric vehicles (EVs) are the most basic technologies that are currently being sought and developed due to their multiple advantages such as performance, safety, and emissions. The acceptance of EVs is related to their performance, cost of purchase, and availability of charging infrastructure. There are three ways to power electric vehicles: conductive charging, wireless charging, and battery replacement (Yilmaz and Krein, 2013). Swap charge (SC) technology provides electric interchangeable batteries for (EVs), which provides an ideal solution to achieve a long highway journey (Zheng et al. 2014; Zhong and Pei, 2020). Conductive

charging is a widely accepted method in the market, but it suffers from some problems, including connection wires, and safety-related problems especially in the humid environment (Rubino, et al. 2017). In addition to the main problem, it needs a relatively long waiting time in the charging station, which is needed to supply the necessary energy, potential traffic congestion in the station, and the need for fixed charging stations (Ahmad, Aqueel et al. 2017; Ahmad et al. 2017). Wireless Power Transfer (WPT), is an easy and safe way to charge the batteries without connecting wires through an air gap (Zamani et al. 2019). This technology is characterized by the vehicle without extended time, and operate safely in the presence of water, rain, or dust. Also, it is dependable during natural catastrophes such as hurricanes, storms, and earthquakes. In addition, it is self-contained and does not require the driver's involvement (Mohamed and Mohammed 2018). There are many applications of

wireless power transmission systems. Figure 1 shows some of these applications (FH 2018; Kuka et al. 2020).

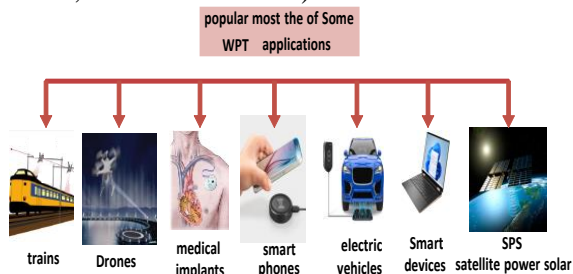

Figure 1. Some applications of wireless power transfer systems (FH 2018)

Wireless charging can be classified into static charging system such as electricity supply stations and parking lots, semi-static charging system such as a traffic lights, and dynamic charging system such as roads of charge by placing the main coils. The dynamic charging are usually rectangular under the ground, in special ways to address the problem of waiting at charging stations and reduce the size and number of batteries,

which will reduce the cost and enjoy a long trip when using such ways. (Lu et al. 2016; Patil et al. 2017). Figure 2 shows a diagram that divides wireless power transmission technology into categories. The four basic types of WPT technology include far-field transmission, near-field transmission, mechanical force, and acoustic (Mohamed et al. 2020; Roes et al. 2013). The far-field transmission systems are microwave power transfer (MPT), laser power transfer (LPW), radio power transfer (RPW), and solar power satellite (SPS). While near-field transmission systems are capacitive power transfer (CPT), inductive power transfer (IPT), without or with resonance circuits. Energy transfer efficiency depends on the air gap and alignment between coil source and receiver (Moon et al. 2014; Van Der Pijl et al. 2013). In this paper, the near magnetic field of wireless transmission technology, which is specialized in charging cars with acceptable efficiency.

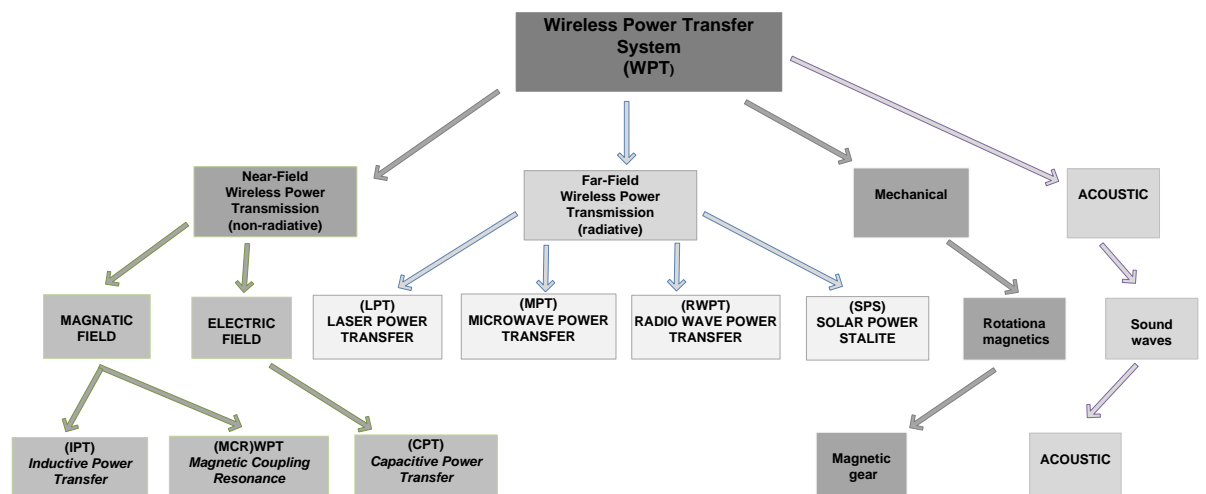

Figure 2. Classifications of wireless power transfer systems.

Each of these four systems of WPT technology has goals, advantages, and disadvantages. TABLE 1 presents the most popular near and far field systems for

wireless power transmission systems and shows the most important advantages of each system as well as the disadvantages of these systems

TABLE 1, Advantages and disadvantages of the most popular WPT systems (Jin and Zhou 2019)

		Advantages	Disadvantages
NEAR-FIELD	CPT	<ul style="list-style-type: none"> <li>-High power transmission.</li> <li>-Energy is transmitted through metallic bodies(Hasan et al. 2020).</li> <li>-Low losses due to eddy currents.</li> <li>-Low weight, cost, and simplicity ( Mitchell Kline et al 2011 ; Lu, Fei et al 2017).</li> <li>-It is used for small applications(Hasan et al. 2020).</li> </ul>	<ul style="list-style-type: none"> <li>-Low efficiency (70-80%).(Detka and Górecki 2022)</li> <li>-Short distance (several millimetres).</li> </ul>
	IPT	<ul style="list-style-type: none"> <li>-High efficiency of more than 90% (Kürschner et al. 2013).</li> <li>-Large transmission power up to several kilowatts (Kim et al. 2015).</li> <li>-Suitable for all devices, from portable devices to electric cars and trains ( Covic, Grant A et al 2013 ).</li> </ul>	<ul style="list-style-type: none"> <li>-Small transmission distance (cm-m).</li> <li>-Eddy's current losses to nearby metals.</li> <li>-Magnetic fields affect living organisms if they exceed the permissible limits.(Mahesh et al. 2021).</li> </ul>
FAR-FIELD	MPT	<ul style="list-style-type: none"> <li>-Long and efficient transmission, a distance of several kilometres. (Zhu et al. 2021).</li> <li>-Use and suitable for mobile phones.(Huang and Zhou 2015)</li> <li>-Transmission of several kilowatts of power.</li> </ul>	<ul style="list-style-type: none"> <li>-Very low efficiency less than 10%.(Detka and Górecki 2022)</li> <li>-Implementation complex.</li> </ul>
	LPT	<ul style="list-style-type: none"> <li>-Long and efficient transmission, a distance of several kilometres (Jin and Zhou 2019).</li> <li>-Use and suitable for mobile phone equipment (Yu and Chen 2021).</li> <li>-Transmission of several kilowatts of power.</li> </ul>	<ul style="list-style-type: none"> <li>-Low application efficiency of less than 20%.(Jin and Zhou 2019)</li> <li>-Line of sight into the receiver.</li> </ul>

## 2 Wireless Power Transfer Methods

In general, wireless electric vehicle charging systems (WEVCS) is designed for traditional inductive power transfer (IPT), capacitive wireless power transfer (CWPT), resonant inductive power transfer (RIPT), and magnetic gear wireless power transfer (MGWPT) ( Covic, Grant Anthony, and John Talbot Boys 2013; Kalwar, Aamir et al. 2015). Inductive power transfer is the most common type (Mohamed and Mohammed 2018), the magnetic fields are used to transfer power between the transmitter and receiver coils. IPT system depends on the inductive coupling between the two coils as shown in Figure 3, (Mayordomo et al. 2013). This technique is only acceptable for short and limited distances where it works well. As the distance increases, the transmitted power will decrease.

The IPT system is still under development for longer distances (Dai et al. 2015). By increasing the air gap between the two coils, a relatively small amount of magnetic flux correlation can be captured by the receiving coil (Vijayakumaran et al. 2016).

While by inserting compensating resonators at the same resonant frequency on the transmitter and receiver side, the system transmits a large capacity with acceptable efficiency through a large air gap (Ahn and Hong 2013; Zhang and Cheng 2016) . The system quality factor can be improved using high-frequency WPT, which leads to higher transmission efficiency (S. Wang and Dorrell 2013), but this process will increase the switching losses in the electronic circuits. In Figure 3 shows the main parts of a wireless power transfer system, and namely the pads, compensation circuits, and electronic transducers.

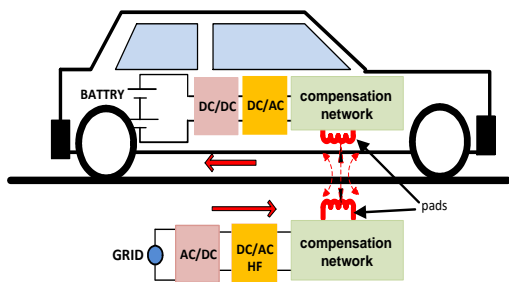

Figure 3. Simple IPT system for charging a car battery.

The second type called the CWPT technology that uses power transmission based on an alternating electric field between the electrodes to transmit power to secondary coils from the primary coils (Lian and Qu 2020). This is characterized by low cost and simplicity (Jing Lian and Xiaohui Qu, Member and Abstract—Capacitive 2019; Panchal, Stegen, and Lu 2018), as well as other characteristics such as weak eddy currents. This technology is used in implanted medical devices and electronics such as laptops, mobile phones, and lamps (Liou et al. 2016; Xie, L. et al 2013), Because of the large air gap, the application of CWPT has been limited for electric vehicles and also because of the high charging power requirements for charging vehicles (Ludois et al. 2014).

The CPT system is better than the IPT system in bearing the horizontal alignment, but in the vertical alignment, the IPT system is the best and it has been used 72% more than the CPT system (Dai and Ludois 2015; Li, Siqi,WeihanLi et al. 2015). The researchers proposed increasing the coupling using a flexible CPT System using bumpers (compressor and flexible) to increase the coupling factor. Also increasing the coupling reduces the air gap during charging case. A prototype was presented in the laboratory at a frequency of 540 kHz with an efficiency up to 83%

and a power greater than 1KW ( Dai, Jiejian Ludois, Daniel C. 2015)

The most famous power transmission system is RIPT due to its high efficiency ( Mohamed, Ahmed A.S., Andrew Meintz, and Lei Zhu. 2019.), extended operating range (Qiu et al. 2014), and amount of transmitted power (Mohamed et al. 2016; Qiu et al. 2013). This type differ from IPT systems by connecting capacitors to coupling circuits to compensate the leakage inductances so that the circuit operates in a resonant state. Figure 4 shows a schematic diagram of the RIPT and CPT system for transmitting power through an electric or magnetic field, the electronic circuit convert AC voltage to high-frequency voltage across the pads to the receiver coils and convert it into a continuous voltage to charge the battery.

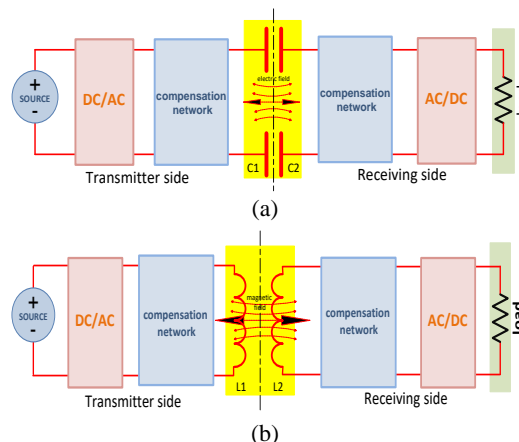

Figure 4. (a)-CPT system, and (b)-RIPT system

### 3 Compensation Circuits

The RIPT systems contain compensating capacitors to reduce the leakage flux due to the wide air gap between the transmitter and receiver coils, which leads to an increase in the input source capacity to be able to transmit the required power (volt-amperes) to the load. The aim of this process is to increases the system losses, and to treat this case compensation

capacitors or the so-called compensation network (Zhang et al. 2019). The connection is either series or parallel or both of them connected to the with receiver and transmitter coils. These networks are designed based on the value of the leakage inductance (Hsieh et al. 2017) or the self-inductance (Aditya and Williamson 2019) where the rate of the spent power (volt-amperes) from the source is reduced and the power factor is improved by canceling the leakage inductance and the interactive component of the primary coil (K. N Mude, Aditya. 2019) It also acts as a filter to block the unwanted frequency and cause a sinusoidal current to flow in the primary coil, this current helps in the soft switching process on the transmitter side, while on the receiver side, it leads to enhance the power and increasing its efficiency to the maximum extent (V. Shevchenko, Husev, O et al. 2019.) As well as increasing its efficiency for misalignment (Wei Zhang et al. 2015), . The compensating network is connected to the coil in four types, which is (series-series SS, series-parallel SP, parallel-parallel PP, and parallel-series PS) as shown in Figure 5. ( Qu, Yanhua et al. 2013; Zhang et al. 2019).The compensation networks type (SS) are used in the systems and applications of electric vehicles because two important advantages provided by this system (Chinthavali et al. 2016; Spanik et al. 2016). The first, the value of the capacitor of receiver and transmitter is independent of the conditions of induction and loading. This means that the resonant frequency does not depend on mutual induction and loads, but rather depends on the self-induction of the transmitter and receiver coil (Vilathgamuwa and Sampath 2015). The second benefit. Such systems maintain a unity power factor by pulling active power as reflected impedance from the receiver coil at the resonant frequency and it does not include a fictitious

component in the transmitter coil (Wang et al. 2005).

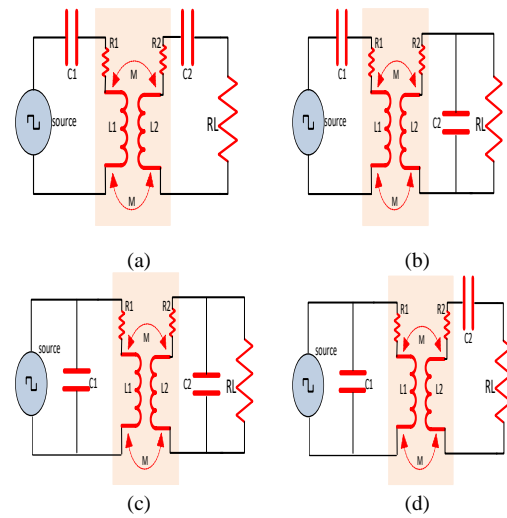

Figure 5. Basic compensation topologies (a) SS topology, (b) SP topology, (c) PP topology, and (d)-PS topology (Bouanou et al. 2021)

Hybrid compensation circuits differ from basic compensation circuits by using more than one element of inductors (L) and capacitors (C). Many previous works are concerned with hybrid compensation, for example: LCC-S, LCC-P in (Fang Liu et al. 2016; Feng et al. 2016), CCL-S (Samanta and Rathore 2015), S-CLC (Y. Wang et al. 2017), LCC-LCC (Deng et al. 2015; Kan et al. 2017; Li et al. 2015), LCL-LCL (Mingyu et al. 2016), LCL-S (Babaki et al. 2021). Compensation circuits are characterized by flexible design and great reliability, used to increase and improve the control on the primary current, which often used in low-power applications, Figure 6 shows the most popular hybrid compensation circuits.

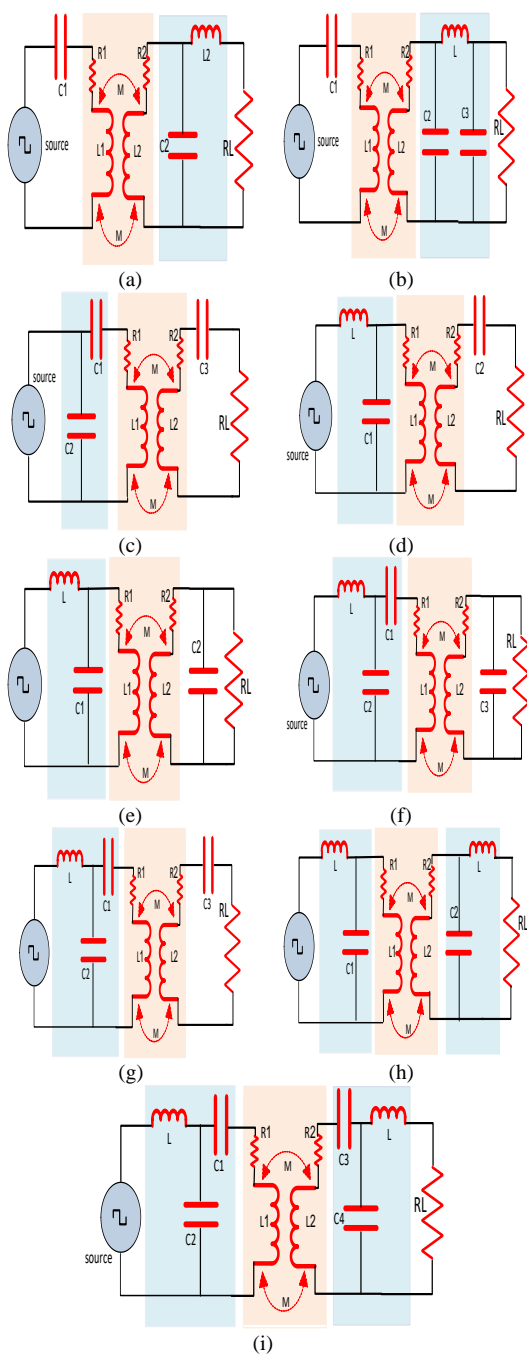

Figure 6. Hybrid compensation topologies of (a) S-LCL, (b) S-CLC, (c) CCL-S, (d) LCL-S, (e) LCL-P, (f) LCC-P, (g) LCC-S, (h) LCL-LCL, (i) LCC-LCC (Houran et al. 2018).

Figure 7 shows the locations and numbers of the components of the compensation circuits in WPT systems.

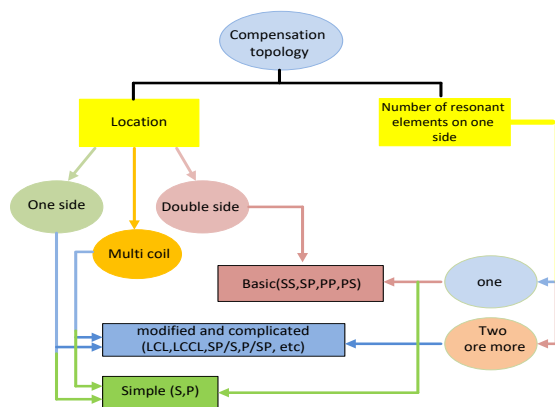

Figure 7. Hybrid compensation topologies (V. Shevchenko, Husev, O et al. 2019.)

### 4 Charging Pads of Wireless Power Transmission Systems

The most important part of WPT systems are the charging pads that make up the RIPT that is responsible for transmitting energy from the source to the vehicle. The pads determine the performance of the system in terms of coupling factor, efficiency, sensitivity to misalignment, and safety.

In the first design, conventional cores are used in transformers. The U-cores (Patil et al. 2017) and E-cores (Qiu et al. 2014) were incompatible with EVs applications are requiring the thickness of the core to achieve the desired flood path, which negatively affects the height of the core above ground, thus requiring extensive modification of the vehicle chassis. Moreover, these designs are fragile, heavy, expensive, and very sensitive to horizontal misalignment. To overcome these design flaws, planar pad structures that are more tolerant of misalignment for stationary and moving vehicle charging have been proposed (A. Ahmad, Alam, and Chabaan 2017). Charging pads are classified into two main types, based on the components

of the coupled flow and the shape of the coil, which are non-polarized pads and polarized pads.

Non-polarized pads (NPPs) consist of a single coil that generates vertical flux components coupled to the receiving coils for power transmission.

Polarizing pads (PoPs) consist of several coils that generate vertical or horizontal

flow components or both of them that are coupled to the receiving coil and transmit energy (Mohamed et al. 2020; Z. Zhang et al. 2019). Table 2 shows the main shapes and sections of the most important pads used in WPT systems and the main features of each type.

**TABLE.2 Types of basic pads and their specifications.**

Expression	The final form	Specifications
<b>Circular pads (CPs)</b> Polarized		<ul style="list-style-type: none"> <li>-Over equivalent air gaps and misalignments, it exhibits less coupling than all the other types of coil geometries of comparable size.</li> <li>-Possess the same level of tolerance for misalignment in all directions.</li> <li>-The most common shape for static EVs systems is still circular.</li> <li>-No matter how well-optimized the design is, it has been demonstrated in (Budhia et al. 2013; Budhia, Covic et al. 2011; Zaheer et al. 2015) that when offset horizontally by around 40% of the pad diameter, CPs display a zero in a mutual coupling.</li> </ul>
<b>Rectangular Pads (RPs)</b> Polarized		<ul style="list-style-type: none"> <li>-dynamic wireless charging is mostly used. (Buja et al 2016; Chen et al. 2016; Choi et al. 2015; Hwang et al. 2017). Better lateral alignment tolerance, small weight, and compact design. (Villa et al. 2012).</li> <li>-compared to the spiral coil, easier to create and design</li> <li>-Rectangular coils are more cost-effective and have superior power-transfer efficiency (Chen et al. 2016).</li> </ul>
<b>Double-D pads (DDPs)</b> Non-Polarized		<ul style="list-style-type: none"> <li>-DDP creates a single-sided flux route with very little leakage flux coming out the rear, making it possible to add aluminum. and get Shielding without significantly decreasing efficiency (Budhia et al. 2013).</li> <li>-In comparison to the NPP, it is also more forgiving of horizontal misalignment.</li> <li>-The flux path's height is equal to that of the H-shaped pads.</li> <li>-When the horizontal misalignment is 34% of the pad length, a higher tolerance only occurs along the width of the pad owing to coupling null.</li> <li>-Because it only produces the parallel portion of the flux, this pad cannot be used with NPPs.</li> </ul>
<b>Double-D Quadrature pads (DDQPs)</b> Non-Polarized		<ul style="list-style-type: none"> <li>-To create the DDQP, a quadrature coil is added to the DDP.</li> <li>-This pad has a better tolerance for lateral and horizontal misalignments and can link and create both the horizontal and the vertical components of a flux.</li> <li>-When compared to the DDQP, the BP offers comparable benefits with less copper.</li> <li>-If utilized as the primary pad, two synchronized inverters are needed, while two synchronized rectifiers are needed for the secondary pad.</li> </ul>

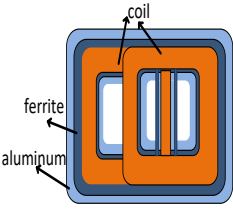
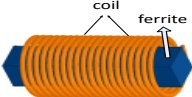
<p><b>Bi-Polar pads (BPPs)</b> Non-Polarized</p>		<ul style="list-style-type: none"> <li>-Other kinds of pads can be used with both the DDQPs and BPs.</li> <li>-Greater misalignment tolerance and interoperability with various pad types.</li> <li>-If utilized as the primary pad, two synchronized inverters are needed, and if used as the secondary pad, two synchronized rectifiers.</li> <li>-Additionally, coupling might decrease by over 13% with an increasing angular misalignment of up to 30° (Ni et al. 2015). They are susceptible to angular misalignments</li> <li>-Additionally, they need a complex control scheme and a position or flux sensor. As a result, the charger's overall price and complexity go up.</li> <li>-The driver of a personal electric vehicle (EV) may park it with a permissible misalignment for static charging.</li> </ul>
<p><b>Solenoid pads (SoPs)</b> Non-Polarized</p>		<ul style="list-style-type: none"> <li>-More misalignment tolerance, lighter, smaller (Budhia, et al. 2010; Nagatsuka et al. 2010; Toshiyuki Fujita, et al. 2016).</li> <li>-employed a solenoid in conjunction with a DD coil because it is lighter, smaller, and easier to put in the car's undercarriage.</li> </ul>

### 5 Pad Parts and Components

The general structure of the pad consists of an electrical conductor often made of Litz wire, and a magnetic core, which mostly using ferrite, and shielding to limit leaky magnetic fields. . Also it consists of materials for packing and preserving the main parts (Mahesh 2021).Figure 8 shows the most important parts of the charging pad.

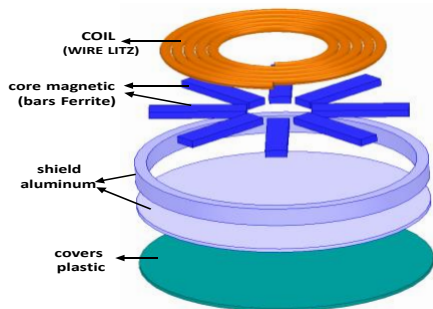

Figure 8. Circular induction pad model, explosive view (Budhia et al. 2011) .

#### 5.1 The Wire

The wires in the pads generate an electromagnetic field. Due to the high frequency of IPT systems, losses of wires are increased in the system due to eddy

currents that effect proximity and the skin. There are two main factors for evaluating the performance and efficiency of IPT on the coupling factor (K), and the quality factor (Q) (Li and Mi 2015; Mizuno et al. 2014).

The coupling factor can be calculated from the following equation (Mohamed et al. 2020):

$$k = \frac{M}{\sqrt{L_1 * L_2}} \tag{1}$$

As for the quality factor, it can be calculated from (Mohamed et al. 2020):

$$Q = \frac{\omega L}{R_{ac}} \tag{2}$$

$$\eta = \frac{KQ}{2+KQ} \tag{3}$$

where (M) is mutual inductance, (L) is self-inductance. Wires with low resistance are used for high frequencies based on Litz Wire (Rossmanith et al. 2011; Shinagawa et al. 2009), tubular conductor (Pantic and Lukic 2013; Sullivan 2008), magneto-coated wire (Konno et al. 2017), magneto-plate wire (Barth, Klaus, and Leibfried



2017; Konno et al. 2017), and aluminum wire (Rossmannith et al. 2011; Tang and Sullivan 2003).

Litz wire consists of many thin copper hairs as in Figure 9 (a) and each individually isolated, to reduce the effect on the skin by reducing the cross-sectional area of each hair, which is no thicker than the depth of the skin (Aditya 2016), to ensure effective usage of the conducting area. The filaments are then woven together so that the location of each filament alternates between the center and the edge of wire. It is often includes several levels to form a stranded wire as in Figure 9 (b) This ensures that the effect of proximity will affect each filament in the same way, thus carrying the same current and reduce the value of the equivalent resistance of the wire (Technischen Fakultät and Helmut Roskopf aus Nürnberg n.d.).

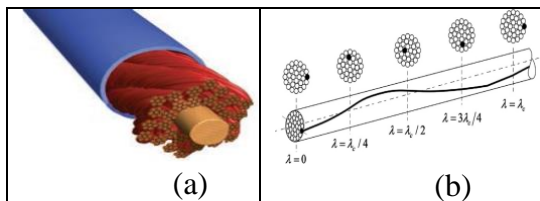

Figure 9. Litz wire: (a) general form, (b) wire position rotation (Lotfi and Lee 1993).

## 5.2 The Ferrite

Another important element in high-energy pad design is the magnetic core represented by the (ferrite core), which often used in high-capacity applications with a large magnetic gap between the transmitter and receiver.

Ferrite is a ceramic material made by mixing and releasing large proportions of (iron III oxide) with one or more complementary metallic elements, such as zinc, nickel, and barium. It is made in many

forms traditional shapes of ferrite are E, I, S, W, U, H, T (Shin et al. 2018) or in the form of one piece, group, or one surface bar as in Figure 10.

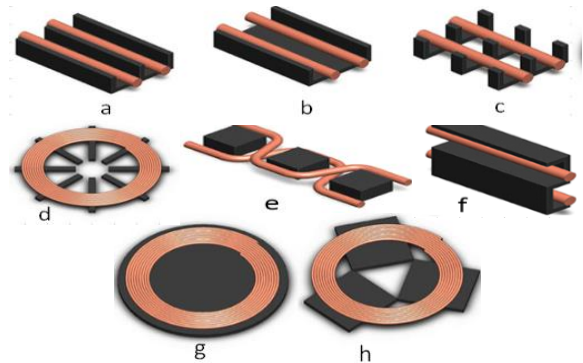

Figure 10. Some forms of Ferrite used in WPT systems: (a) E shape coil, (b) U shape coil, (c) W shape coil, (d) Split surface bars (e) I shape coil, (f) S shape coil, (g) Entire surface, (h) Split surface square (Triviño-Cabrera et al 2020).

Ferrite alloy have a non-conductive with high magnetic permeability that can be easily magnetized and is classified based on its resistance demagnetization to two types: hard and soft ferrite (Roy, Shivakumara, and Anil Kumar 2009). Hard ferrite has a high resistance, so it is difficult to demagnetize. It is used in the manufacture of permanent magnets for applications such as magnets for loudspeakers and small electric motors, while the latter (soft ferrite) has little magnetic resistance so that it can be easily magnetized and demagnetized. The soft ferrite core is used for high-frequency transformers as a conductor of magnetic fields.

The widest ferrite used in IPT systems are (Mn- Zn) and (Ni -Zn) due to their low losses at high frequencies. Many studies dealt with the effect of the ferrite on the mutual inductance of the system and the transmission of power and efficiency (Jeong et al. 2017; Noh, Ko, and Kim 2016). The following Figure 11 shows the

effect of increasing the ferrite on the coupling factor and thus on the efficiency by using the finite element analysis method (FEA) and ANSYS MAXWELL (3D) simulation software. Finite element method is a numerical method of analysis using the strategy of dividing the complex model into very small parts and transforming it into an easy-to-solve system using simple equations and then collecting these solutions to find the final solution ( Basil M,et al. 2013; Bouanou et al. 2021; Saied ,et al .2013).

This program do a lot of solutions related to magnetic fields with high accuracy (Basil M Saied, et al. 2012), and other programs use the finite element method such as JMAG, COMSO and CST EM STUDIO.

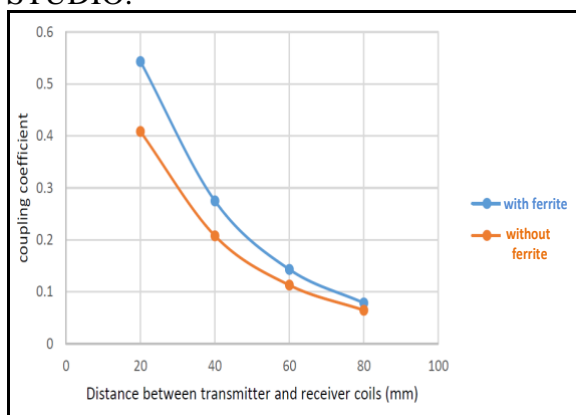

Figure 11. The effect of adding ferrite on the coupling factor of a circular pad.

Figure 12 shows the effect of adding ferrite bars to the pads and its effect on the flux density. The results of the analysis with (ANSYS MAXWELL 3D) show an increase in flux density for pads containing ferrite, which appears in the color red, and represents the highest value of the flux density.

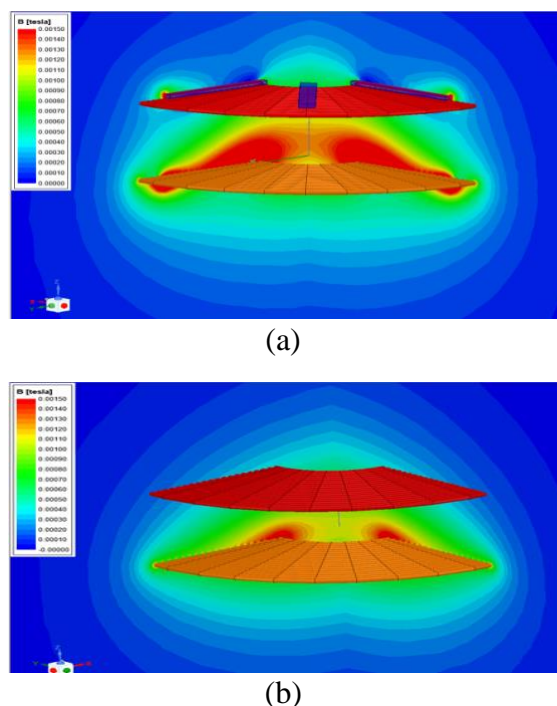

Figure 12. Effect of adding ferrite on the flux density: (a) Circular pad with ferrites, (b) Circular pad without ferrites.

### 5.3 Shielding

Due to the presence of some electromagnetic fields leaking around WPT systems, these fields may exceed the safe limits stated in international standards and guidelines that, may pose a threat to nearby living organisms and their safety ( Zhang, Wei et al. 2015). Therefore, shielding is used to reduce flux around the system and improve coupling, the Figure 13 shows the main types of shielding.

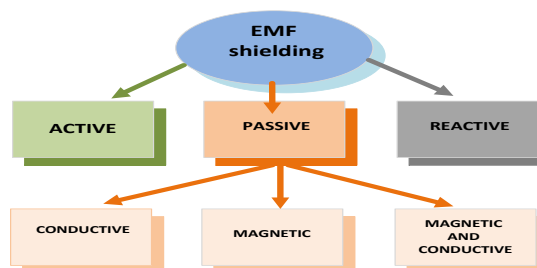

Figure 13. Electromagnetic shielding for WPT systems.

Passive shielding is commonly used due to its simplicity, durability, and inexpensive implementation. Either a magnetic material such as ferrite or a conductive material such as aluminum or both is added (Patil et al. 2017), as in Figure 14, where this shielding helps the magnetic fields to go through them and prevent leakage around the system and enhance the mutual inductance between the transmitter and receiver (Mohammad, M. et al. 2019.).

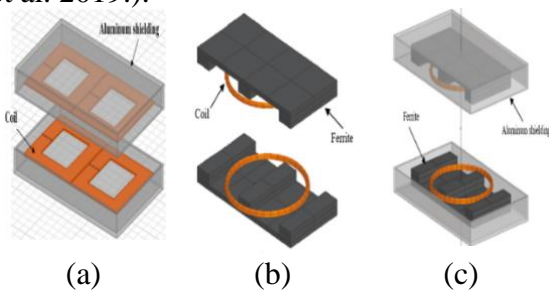

Figure 14. Passive shielding for WPT systems

(a) conductive, (b) magnetic, and (c) conductive and magnetic (Mohamed et al. 2020)

To overcome the disadvantages of passive shielding represented by the heavyweight, high cost, and limitations of high power systems (greater than 100 kW), active shielding has been adopted by adding external coils with opposite polarity to the original coil to generate cancel fields. Its disadvantages include increased cost and copper losses (Campi et al. 2020; Cruciani et al. 2019).

Since the current passing through the active shielding coils depends on the same current passing through the base coils, which in turn leads to an increase in the

input capacity and an increase in the cost of the system, resonant reactive shielding has been proposed by introducing a capacitor and resistance to the shielding coil. Where this method uses the leaking field as a power source, to cancel the non-fields desirability and high, where the efficiency is greater, and the value of the current can be controlled by controlling the value of the connected capacitor. Figure 15 shows active and reactive shielding.

TABLE 3. Shows a comparison among several studies of WPT systems. The performance of these systems are evaluated by some factors like, the amount of transmitted power, the compensation circuits used, the amount of the air gap between the transmitter and receiver, the system efficiency for each study, and the program used if any.

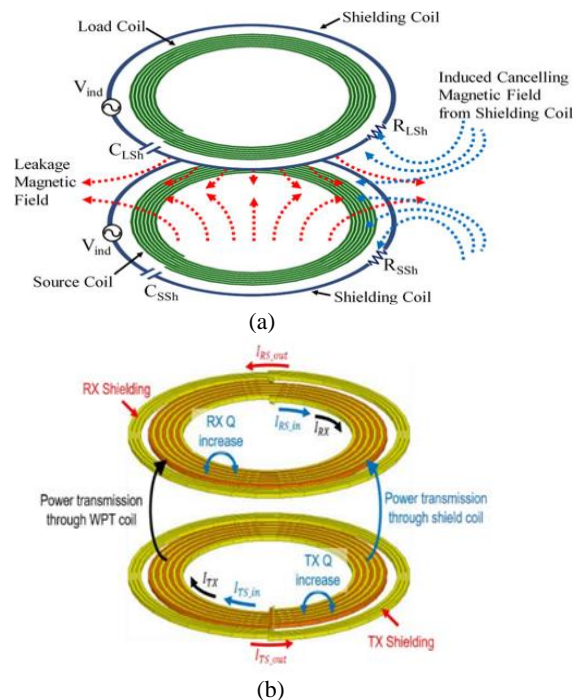

Figure 15. Shielding for WPT systems (a) active, and (b) reactive (Kim and Ahn 2021; Park et al. 2017)

TABLE.3 Previous studies show the amount of transferred power and the air gap between the pads.

Ref.	Pad Shape	Transmitted Power (w)	Frequency (kHz)	Compensation Topology	Efficiency (%)	Inverter Type	Air Gap (mm)	Simulation Program
(Moon et al. 2016)	MULTI CPs	3.3k	90	SS	96.56	Full 3phase	200	-
(Zheng et al. 2015)	CPs	4k	10-300	SS	96.6-98	full	40-80	FEA
(Hsieh et al. 2017)	CPs	500	182	SS	90	full	150	-
(Buja et al. 2015)	CPs	560	85	SS	89	H-bridge	150	FEA/COMS OL
(Diekhans and De Doncker 2015)	CPs	3k	35	SS	95.8-92.1		100-170	FEA/JMAG
(Pathipati et al. 2016)	PoPs	5	41.5	SP	80		10	FEA/JMAG
(Throngnumchai et al. 2013)	Tx-CPs Rx-RPs	1k	90	SP-SP	90		100	-
(Mingyu et al. 2016)	RPs	3.3k	85	SS LCL-LCL	93.1 89.9		100	multisum
(Zhao, et al. 2017)	DDPs	3.3k	89	LCL-LC	91	full	120	-
(Yang et al. 2021)	TX-RPs RX-DDPs	3.3k	80-90	LCC-DSLCC	95	H-bridge	100-150	FEA

## 6 Conclusion

This paper presents a comprehensive study of WPT systems, a review on the most important parts and components of these systems to assist researchers and designers in choosing the appropriate compensation topology, and the optimal design of the pads structure. This is done to overcome the problem of improper alignment and the optimal distance between coils to transfer power with the highest efficiency. It uses in modern technologies such as automobiles and other applications to overcome the challenges of cost, pollution, health and

safety. The study focused on the base pads and their different types in terms of coupling factor, structure shape, and effect of variation on these pads. In addition, it focused on the type of wires to reduce the crust phenomenon and proximity depending on Litz wire. Beside that the magnetic materials and their effect on the coupling factor and the direction of magnetic fields by modelling two circular coils using a program ANSYS MAXWELL supported by shapes and values. Also, methods that used for reducing leaky magnetic fields and types of shielding. Finally, a table of different

studies that use more than different compensation and transmission circuits of different power through variable air gaps have been mentioned to support these studies.

## 7 References

- Aditya, Kunwar. " Design and Implementation of an Inductive Power Transfer System for Wireless Charging of Future Electric Transportation", PhD Thesis, University of Ontario Institute of Technology Oshawa, Canada, Aug. 2016.
- Aditya, Kunwar, and Sheldon S. Williamson. 2019. "Design Guidelines to Avoid Bifurcation in a Series-Series Compensated Inductive Power Transfer System." *IEEE Transactions on Industrial Electronics* 66(5): 3973–82.
- Ahmad, Aqueel, Mohammad Saad Alam, and Rakan Chabaan. 2017. "A Comprehensive Review of Wireless Charging Technologies for Electric Vehicles." *IEEE Transactions on Transportation Electrification* 4(1): 38–63.
- Ahmad, Furkan, Mohammad Saad Alam, and Mohammad Asaad. 2017. "Developments in XEVs Charging Infrastructure and Energy Management System for Smart Microgrids Including XEVs." *Sustainable Cities and Society* 35: 552–64.
- Ahn, Dukju, and Songcheol Hong. 2013. "A Study on Magnetic Field Repeater in Wireless Power Transfer." *IEEE Transactions on Industrial Electronics* 60(1): 360–71. pp. 360-371, doi:10.1109/TIE.2012.2188254
- Antar, Rakan Khalil, Taha Ahmed Hussein, Abdallah Mohamed Abdullah, and Taha Ahmed Hussein. 2022. "Design and Implementation of Reduced Number of Switches for New Multilevel Inverter Topology without Zero-Level State." 13(1): 401–10.
- Babaki, Amir, Sadegh Vaez-Zadeh, Ali Zakerian, and Grant A. Covic. 2021. "Variable-Frequency Retuned WPT System for Power Transfer and Efficiency Improvement in Dynamic EV Charging with Fixed Voltage Characteristic." *IEEE Transactions on Energy Conversion* 36(3): 2141–51.
- Barth, Daniel, Benjamin Klaus, and Thomas Leibfried. 2017. "Litz Wire Design for Wireless Power Transfer in Electric Vehicles." In *2017 IEEE Wireless Power Transfer Conference (WPTC)* (pp. 1-4).
- Basil M Saied, Ahmed J. Ali. 2013. "Hybrid Mesh Technique to Model a Deep Bar Induction Motor Using Time Stepping Finite Elements Analysis(ENG)." *AL-Rafdain Engineering Journal (AREJ)* 21(3): 90–98.
- Bouanou,T., El Fadil, H., Lassioui, A., Assaddiki, O., and Njili, S. 2021. "Analysis of Coil Parameters and Comparison of Circular, Rectangular, and Hexagonal Coils Used in Wpt System for Electric Vehicle Charging." *World Electric Vehicle Journal* 12(1).45.
- Budhia, Mickel, John T. Boys, Grant A. Covic, and Chang Yu Huang. 2013. "Development of a Single-Sided Flux Magnetic Coupler for Electric Vehicle IPT Charging Systems." *IEEE Transactions on Industrial*

- Electronics* 60(1): 318–28.
- Budhia, Mickel, Grant A. Covic, and John T. Boys. 2011. “Design and Optimization of Circular Magnetic Structures for Lumped Inductive Power Transfer Systems.” *IEEE Transactions on Power Electronics* 26(11): 3096–3108.
- Budhia, M., Covic, G., & Boys, J. (2010, November). A new IPT magnetic coupler for electric vehicle charging systems. In *IECON 2010-36th Annual Conference on IEEE Industrial Electronics Society* (pp. 2487-2492)..
- Buja, Giuseppe, Manuele Bertoluzzo, and Hemant Kumar Dashora. 2016. “Lumped Track Layout Design for Dynamic Wireless Charging of Electric Vehicles.” *IEEE Transactions on Industrial Electronics* 63(10): 6631–40.
- Buja, Giuseppe, Manuele Bertoluzzo, and Kishore Naik Mude. 2015. “Design and Experimentation of WPT Charger for Electric City Car.” *IEEE Transactions on Industrial Electronics* 62(12): 7436–47.
- Campi, Tommaso, Silvano Cruciani, Francescaromana Maradei, and Mauro Feliziani. 2020. “Magnetic Field Mitigation by Multicoil Active Shielding in Electric Vehicles Equipped with Wireless Power Charging System.” *IEEE Transactions on Electromagnetic Compatibility* 62(4): 1398–1405.
- Chen, Weitong, Chunhua Liu, Christopher H.T. Lee, and Zhiqiang Shan. 2016. “Cost-Effectiveness Comparison of Coupler Designs of Wireless Power Transfer for Electric Vehicle Dynamic Charging.” *Energies* 9(11)..906
- Chinthavali, Madhu, Zhiqiang Wang, and Steven Campbell. 2016. “Analytical Modeling of Wireless Power Transfer (WPT) Systems for Electric Vehicle Application.” 2016 *IEEE Transportation Electrification Conference and Expo, ITEC* Dearborn, MI, 2016, pp. 1-8, doi: 10.1109/ITEC.2016.7520246.
- Choi, Su Y., Beom W. Gu, Seog Y. Jeong, and Chun T. Rim. 2015. “Advances in Wireless Power Transfer Systems for Roadway-Powered Electric Vehicles.” *IEEE Journal of Emerging and Selected Topics in Power Electronics* 3(1): 18–36.?
- Covic, Grant A., and John T. Boys. 2013. “Inductive Power Transfer.” *Proceedings of the IEEE* 101 (6): 1276–89. <https://doi.org/10.1109/JPROC.2013.2244536>
- Covic, Grant Anthony, and John Talbot Boys. 2013. “Modern Trends in Inductive Power Transfer for Transportation Applications.” *IEEE Journal of Emerging and Selected Topics in Power Electronics* 1(1): 28–41.
- Cruciani, Silvano, Tommaso Campi, Francescaromana Maradei, and Mauro Feliziani. 2019. “Active Shielding Design for Wireless Power Transfer Systems.” *IEEE Transactions on Electromagnetic Compatibility* 61(6): 1953–60.
- Dai, and D. C. Ludois, 2015 “A Survey of Wireless Power Transfer and a Critical Comparison of Inductive and Capacitive Coupling for Small Gap Applications,” *IEEE Transactions on Power Electronics*, 30(11), 6017-6029.
- Dai, Jiejian, and Daniel C. (2015, March). Wireless electric vehicle charging via

- capacitive power transfer through a conformal bumper. In 2015 IEEE Applied Power Electronics Conference and Exposition (APEC) (pp. 3307-3313).
- Deng, Deng, Junjun, Weihan Li, Trong Duy Nguyen, Siqi Li, and Chunting Chris Mi. 2015. "Compact and Efficient Bipolar Coupler for Wireless Power Chargers: Design and Analysis." *IEEE Transactions on Power Electronics*, 30(11), 6130-6140.
- Detka, Kalina, and Krzysztof Górecki. 2022. "Wireless Power Transfer—A Review." *Energies* 15(19).
- Diekhans, Tobias, and Rik W. De Doncker. 2015. "A Dual-Side Controlled Inductive Power Transfer System Optimized for Large Coupling Factor Variations and Partial Load." *IEEE Transactions on Power Electronics* 30(11): 6320–28.
- Lu, Fei, Hua Zhang, and Chris Mi. 2017. "A Review on the Recent Development of Capacitive Wireless Power Transfer Technology." *Energies*. *Energies*, 10(11), 1752.
- Fang Liu, Yiming Zhang, Kainan Chen, Zhengming Zhao, Liqiang Yuan. 2016. "A Comparative Study of Load Characteristics of Resonance Types in Wireless Transmission Systems." *IEEE*: 203–6.
- Feng, Hao, Cai, T., Duan, S., Zhao, J., Zhang, X., & Chen, C. 2016. "An LCC-Compensated Resonant Converter Optimized for Robust Reaction to Large Coupling Variation in Dynamic Wireless Power Transfer." *IEEE Transactions on Industrial Electronics* 63(10): 6591–6601.
- FH, Sumi, Lokesh Dutta, Farhana Sarker. 2018. "Future with Wireless Power Transfer Technology." *Journal of Electrical & Electronic Systems* 07(04).
- Hasan, Khairul Kamarudin, Saat, S., Yusop, Y., Husin, H., Hussin, M. Z., & Yusoff, Z. M. 2020. "Analysis and Design Capacitive Power Transfer (CPT) System for Low Application Using Class-E LCCL Inverter by Investigate Distance between Plates Capacitive." *In Journal of Physics: Conference Series (Vol. 1529, No. 3, p. 032094)*. *IOP Publishing*
- Houran, Mohamad Abou, Xu Yang, and Wenjie Chen. 2018. "Magnetically Coupled Resonance Wpt: Review of Compensation Topologies, Resonator Structures with Misalignment, and Emi Diagnostics." *Electronics (Switzerland)* 7(11).
- Hsieh, Yao Ching, Lin, Z. R., Chen, M. C., Hsieh, H. C., Liu, Y. C., & Chiu, H. J. 2017. "High-Efficiency Wireless Power Transfer System for Electric Vehicle Applications." *IEEE Transactions on Circuits and Systems II: Express Briefs* 64(8): 942–46.
- Huang, Kaibin, and Xiangyun Zhou. 2015. "Mobile Communications by Microwave Power Transfer." (June): 86–93.
- Hwang, Karam, Cho, J., Kim, D., Park, J., Kwon, J. H., Kwak, S. I., ... & Ahn, S. 2017. "An Autonomous Coil Alignment System for the Dynamic Wireless Charging of Electric Vehicles to Minimize Lateral Misalignment." *Energies* 10(3).315.
- Jeong, Seungtaek, Song, J., Kim, H., Lee, S., Kim, J., Lee, J., & Song, J. 2017. "Design and Analysis of Wireless Power Transfer System Using Flexible Coil and Shielding Material

- on Smartwatch Strap.” *WPTC 2017 - Wireless Power Transfer Conference*: 1–3.
- Jin, Ke, and Weiyang Zhou. 2019. “Wireless Laser Power Transmission: A Review of Recent Progress.” *IEEE Transactions on Power Electronics* 34(4): 3842–59.
- Jing Lian and Xiaohui Qu, Member, IEEE, and Abstract—Capacitive. 2019. “Design of a Double-Sided LC Compensated Capacitive Power Transfer System with Capacitor Voltage Stress Optimization.”
- K. N. Mude, and Aditya, K. (2019). Comprehensive review and analysis of two-element resonant compensation topologies for wireless inductive power transfer systems. *Chinese Journal of Electrical Engineering*, 5(2), 14-31.
- Kalwar, M. Aamir, and S. Mekhilef, “Inductively coupled power transfer (ICPT) for electric vehicle charging - A review,” *Renew. Sustain. Energy Rev.*, vol. 47, pp. 462–475, 2015, doi: 10.1016/j.rser.2015.03.040
- Kan, Tianze, Nguyen, T. D., White, J. C., Malhan, R. K., & Mi, C. C. 2017. “A New Integration Method for an Electric Vehicle Wireless Charging System Using LCC Compensation Topology: Analysis and Design.” *IEEE Transactions on Power Electronics* 32(2): 1638–50.
- Kim, Jae Hee, Byung-Song Lee, Jun-Ho Lee, Seung-Hwan Lee, Chan-Bae Park, Shin-Myung Jung, Soo-Gil Lee, Kyung-Pyo Yi, Jeihoon Baek. 2015. “Development of 1-MW Inductive Power Transfer System for a High-Speed Train.” *IEEE Transactions on Industrial Electronics* 62(10): 6242–50.
- Kim, Jedok, and Seungyoung Ahn. 2021. “Dual Loop Reactive Shield Application of Wireless Power Transfer System for Leakage Magnetic Field Reduction and Efficiency Enhancement.” *IEEE Access* 9: 118307–23.
- Konno, Yasuyuki, Yamamoto, T., Chai, Y., Tomoya, D., Bu, Y., & Mizuno, T. 2017. “Basic Characterization of Magnetocoated Wire Fabricated Using Spray Method.” *IEEE Transactions on Magnetics* 53(11): 13–19.
- Kuka, Sokol, Kai Ni, and Mohammed Alkahtani. 2020. “A Review of Methods and Challenges for Improvement in Efficiency and Distance for Wireless Power Transfer Applications.” *Power Electronics and Drives* 5(1): 1–25.
- Kürschner, Daniel, Christian Rathge, and Ulrich Jumar. 2013. “Design Methodology for High Efficient Inductive Power Transfer Systems with High Coil Positioning Flexibility.” *IEEE Transactions on Industrial Electronics* 60(1): 372–81.
- Li, Siqi, Li, W., Deng, J., Nguyen, T. D., & Mi, C. C., 2015. “A Double-Sided LCC Compensation Network and Its Tuning Method for Wireless Power Transfer.” *IEEE Transactions on Vehicular Technology* 64(6): 2261–73.
- Li, Siqi, and Chunting Chris Mi. 2015. “Wireless Power Transfer for Electric Vehicle Applications.” *IEEE Journal of Emerging and Selected Topics in Power Electronics* 3(1): 4–17.
- Lian, Jing, and Xiaohui Qu. 2020. “Design of a Double-Sided LC Compensated Capacitive Power Transfer System with Capacitor Voltage Stress



- Optimization.” *IEEE Transactions on Circuits and Systems II: Express Briefs* 67(4): 715–19.
- Liou, Chong Yi, Chi Jung Kuo, and Shau Gang Mao. 2016. “Wireless-Power-Transfer System Using Near-Field Capacitively Coupled Resonators.” *IEEE Transactions on Circuits and Systems II: Express Briefs* 63(9): 898–902.
- Lotfi, Ashraf W., and Fred C. Lee. 1993. “High Frequency Model for Litz Wire for Switch-Mode Magnetics.” *Conference Record - IAS Annual Meeting (IEEE Industry Applications Society)* 2(703): 1169–75.
- Lu, Xiao, Wang, P., Niyato, D., Kim, D. I., & Han, Z. 2015. “Wireless Charging Technologies: Fundamentals, Standards, and Network Applications.” *IEEE Communications Surveys and Tutorials* 18(2): 1413–52.
- Ludois, D. C., Erickson, M. J., & Reed, J. K. 2014. “Aerodynamic Fluid Bearings for Translational and Rotating Capacitors In Non-Contact Capacitive Power Transfer Systems.” *IEEE Transactions on Industry Applications*, 50(2), 1025-1033.
- Mahesh, Aganti, Bharatiraja Chokkalingam, and Lucian Mihet-Popa. 2021. “Inductive Wireless Power Transfer Charging for Electric Vehicles-A Review.” *IEEE Access*, 9, pp. 137667–137713. doi: 10.1109/ACCESS.2021.3116678
- Mayordomo, Iker. , Dräger, T., Spies, P., Bernhard, J., & Pflaum, A. 2013. “An Overview of Technical Challenges and Advances of Inductive Wireless Power Transmission.” *Proceedings of the IEEE* 101(6): 1302–11.
- Mingyu Park, Van Thuan Nguyen, Seung-Duck Yu et al. 2016. “A Study of Wireless Power Transfer Topologies for 3.3 KW and 6.6 KW Electric Vehicle Charging Infrastructure.” In *2016 IEEE Transportation Electrification Conference and Expo, Asia-Pacific (ITEC Asia-Pacific)* IEEE: 689–92.
- Mitchell Kline, Igor Izyumin, Bernhard Boser, and Seth Sanders. 2011. “Capacitive Power Transfer for Contactless Charging.” *IEEE*: 1398–1404.
- Mizuno, Tsutomu, Ueda, T., Yachi, S., Ohtomo, R., & Goto, Y. 2014. “Dependence of Efficiency on Wire Type and Number of Strands of Litz Wire for Wireless Power Transfer of Magnetic Resonant Coupling.” *IEEE Journal of Industry Applications* 3(1): 35–40..
- Mohamed, Ahmed A.S., Dual Allen, Tarek Youssef, and Osama Mohammed. 2016. “Optimal Design of High Frequency H-Bridge Inverter for Wireless Power Transfer Systems in EV Applications.” *EEEIC 2016 - International Conference on Environment and Electrical Engineering*. pp1-6
- Mohamed, Ahmed A.S., Andrew Meintz, and Lei Zhu. 2019. “System Design and Optimization of In-Route Wireless Charging Infrastructure for Shared Automated Electric Vehicles.” *IEEE Access* 7(c): 79968–79.
- Mohamed, Ahmed A.S., and Osama Mohammed. 2018. “Physics-Based Co-Simulation Platform with Analytical and Experimental Verification for Bidirectional IPT System in EV Applications.” *IEEE Transactions on Vehicular*

- Technology* 67(1): 275–84.
- Mohamed, Ahmed A.S., Ahmed A. Shaier, Hamid Metwally, and Sameh I. Selem. 2020. “A Comprehensive Overview of Inductive Pad in Electric Vehicles Stationary Charging.” *Applied Energy* 262.
- Mohammad, M., Pries, J., Onar, O., Galigekere, V. P., Su, G. J., Anwar, S., and Patil, D. 2019 “Design of an EMF Suppressing Magnetic Shield for a 100-KW DD-Coil Wireless Charging System for Electric Vehicles”.ar. In 2019 IEEE Applied Power Electronics Conference and Exposition (APEC) (pp. 1521-1527).
- Basil M Saied, and Ahmed Jadaan Ali. (2012, November). Determination of deep bar cage rotor induction machine parameters based on finite element approach. In 2012 First National Conference for Engineering Sciences (FNCES 2012) (pp. 1-6).
- Moon, Sang Cheol, and Gun Woo Moon. 2016. “Wireless Power Transfer System with an Asymmetric Four-Coil Resonator for Electric Vehicle Battery Chargers.” *IEEE Transactions on Power Electronics* 31(10): 6844–54.
- Moon, Sangcheol, Kim, B. C., Cho, S. Y., Ahn, C. H., & Moon, G. W.2014. “Analysis and Design of a Wireless Power Transfer System with an Intermediate Coil for High Efficiency.” *IEEE Transactions on Industrial Electronics* 61(11): 5861–70.
- Nagatsuka, Y., Ehara, N., Kaneko, Y., Abe, S., and Yasuda, T. 2010. “Compact Contactless Power Transfer System for Electric Vehicles.” 2010 *International Power Electronics Conference - ECCE Asia*, *IPEC 2010*: 807–13.
- Ni, Wei, Collings, I. B., Wang, X., Liu, R. P., Kajan, A., Hedley, M., & Abolhasan, M. 2015. “Radio Alignment for Inductive Charging of Electric Vehicles.” *IEEE Transactions on Industrial Informatics* 11(2): 427–40.
- Noh, Eonsu, Kwang Hee Ko, and Kangwook Kim. 2016. “Transmitter Coil System without Ferrite in Wireless Power Transfer.” *Electronics Letters* 52(5): 392–93.
- Panchal, Chirag, Sascha Stegen, and Junwei Lu. 2018. “Review of Static and Dynamic Wireless Electric Vehicle Charging System.” *Engineering Science and Technology, an International Journal* 21(5): 922–37.
- Pantic, Zeljko, and Srdjan Lukic. 2013. “Computationally-Efficient, Generalized Expressions for the Proximity-Effect in Multi-Layer, Multi-Turn Tubular Coils for Wireless Power Transfer Systems.” *IEEE Transactions on Magnetics* 49(11): 5404–16.
- Park, J., Kim, D., Hwang, K., Park, H. H., Kwak, S. I., Kwon, J. H., and Ahn, S. 2017. “A Resonant Reactive Shielding for Planar Wireless Power Transfer System in Smartphone Application.” *IEEE Transactions on Electromagnetic Compatibility* 59(2): 695–703.
- Pathipati, V. K., Azeez, N. A., Aditya, K., Williamson, S. S., Dohmeier, N., & Botting, C. 2016. “Performance Analysis of a High-Efficiency Multi-Winding Wireless EV Charging System Using U-U and U-I Core Geometries.” 2016 *IEEE Transportation Electrification*

- Conference and Expo, ITEC 2016.* (pp. 1-8).
- Patil, D., McDonough, M. K., Miller, J. M., Fahimi, B., and Balsara, P. T. 2017. "Wireless Power Transfer for Vehicular Applications: Overview and Challenges." *IEEE Transactions on Transportation Electrification* 4(1): 3–37.
- Van Der Pijl, Frank, Pavol Bauer, and Miguel Castilla. 2013. "Control Method for Wireless Inductive Energy Transfer Systems with Relatively Large Air Gap." *IEEE Transactions on Industrial Electronics* 60(1): 382–90.
- Qiu, Chun, K. T. Chau, Tze Wood Ching, and Chunhua Liu. 2014. "Overview of Wireless Charging Technologies for Electric Vehicles." *Journal of Asian Electric Vehicles* 12(1): 1679–85.
- Qiu, Chun, K. T. Chau, Chunhua Liu, and C. C. Chan. 2013. "Overview of Wireless Power Transfer for Electric Vehicle Charging." *2013 World Electric Vehicle Symposium and Exhibition, EVS 2013*: 1–9.
- Qu, Yanhua, Anna Wang, Sheng Lin, and Yangchun Li. 2013. "The Resonance Compensation Circuit Research to Wireless Power Transfer System." *Advanced Materials Research* 614–615: 728–32.
- Roes, Maurice G.L., Jorge L. Duarte, Marcel A.M. Hendrix, and Elena A. Lomonova. 2013. "Acoustic Energy Transfer: A Review." *IEEE Transactions on Industrial Electronics* 60(1): 242–48.
- Rossmannith, Hans, Marc Doebroenti, Manfred Albach, and Dietmar Exner. 2011. "Measurement and Characterization of High Frequency Losses in Nonideal Litz Wires." *IEEE Transactions on Power Electronics* 26(11): 3386–94.
- Roy, Debangsu, C. Shivakumara, and P. S. Anil Kumar. 2009. "Observation of the Exchange Spring Behavior in Hard-Soft-Ferrite Nanocomposite." *Journal of Magnetism and Magnetic Materials* 321(5): 12–15.
- Rubino, Luigi, Clemente Capasso, and Ottorino Veneri. 2017. "Review on Plug-in Electric Vehicle Charging Architectures Integrated with Distributed Energy Sources for Sustainable Mobility." *Applied Energy* 207: 438–64. <http://dx.doi.org/10.1016/j.apenergy.2017.06.097>.
- Saied, Basil, and Ahmed Ali. 2013. "Fault Prediction of Deep Bar Cage Rotor Induction Motor Based on FEM." *Progress In Electromagnetics Research B* (53): 291–314.
- Samanta, Suvendu, and Akshay Kumar Rathore. 2015. "A New Current-Fed CLC Transmitter and LC Receiver Topology for Inductive Wireless Power Transfer Application: Analysis, Design, and Experimental Results." *IEEE Transactions on Transportation Electrification* 1(4): 357–68.
- Shin, Yujun et al. 2018. "Wireless Power Transfer System for Unmanned Vehicle Using T-Shape Ferrite Structure." *2018 IEEE International Symposium on Electromagnetic Compatibility and 2018 IEEE Asia-Pacific Symposium on Electromagnetic Compatibility, EMC/APEMC 2018*: 117.
- Shinagawa, H., Suzuki, T., Noda, M., Shimura, Y., Enoki, S., and Mizuno, T. 2009. "Theoretical Analysis of AC Resistance in Coil Using

- Magnetoplated Wire.” *IEEE Transactions on Magnetics* 45(9): 3251–59.?
- Spanik, Pavol, Michal Frivaldsky, Peter Drgona, and Viliam Jaros. 2016. “Analysis of Proper Configuration of Wireless Power Transfer System for Electric Vehicle Charging.” *ELEKTRO 2016 - 11th International Conference, Proceedings*: 231–37.
- Sullivan, Charles R. 2008. “Aluminum Windings and Other Strategies for High-Frequency Magnetics Design in an Era of High Copper and Energy Costs.” *IEEE Transactions on Power Electronics* 23(4): 2044–51.
- Tang, Xu, and Charles R. Sullivan. 2003. “Stranded Wire with Uninsulated Strands as a Low-Cost Alternative to Litz Wire.” *PESC Record - IEEE Annual Power Electronics Specialists Conference* 1: 289–95.
- Technischen Fakultät, Der, and Andreas Helmut Roskopf aus Nürnberg. 2018. Calculation of Frequency Dependent Power Losses in Inductive Systems with Litz Wire Conductors by a Coupled Numeric (Doctoral dissertation, Friedrich-Alexander-Universität Erlangen-Nürnberg (FAU)).
- Throngnumchai, Kraisorn, Akihiro Hanamura, Yuji Naruse, and Kazuhiro Takeda. 2013. “Design and Evaluation of a Wireless Power Transfer System with Road Embedded Transmitter Coils for Dynamic Charging of Electric Vehicles.” *World Electric Vehicle Journal* 6(4): 848–57.
- Toshiyuki Fujita, Tomio Yasuda, and Hirofumi Akagi 2016. “A Dynamic Wireless Power Transfer System Applicable to a Stationary System.” *IEEE Transactions on Industry Applications*, 53(4), 3748-3757.
- Triviño-Cabrera, A., González-González, J. M., & Aguado, J. A. (2020). Wireless power transfer for electric vehicles: foundations and design approach.
- V. Shevchenko, Husev, O., Strzelecki, R., Pakhaliuk, B., Poliakov, N., and Strzelecka, N. (2019). Compensation topologies in IPT systems: Standards, requirements, classification, analysis, comparison and application. *IEEE Access*, 7, 120559-120580
- Vijayakumaran Nair, Vijith, and Jun Rim Choi. 2016. “An Efficiency Enhancement Technique for a Wireless Power Transmission System Based on a Multiple Coil Switching Technique.” *Energies* 9(3). doi: 10.3390/en9030156.
- Vilathgamuwa, D. M., and J. P.K. Sampath. 2015. “Wireless power transfer (WPT) for electric vehicles (EVS)—Present and future trends. ” *Plug In Electric Vehicles in Smart Grids: Integration Techniques*, 33-60.
- Villa, Juan L., Jesús Sallán, José Francisco Sanz Osorio, and Andrés Llombart. 2012. “High-Misalignment Tolerant Compensation Topology for ICPT Systems.” *IEEE Transactions on Industrial Electronics* 59(2): 945–51.
- Wang, Chwei Sen, Oskar H. Stielau, and Grant A. Covic. 2005. “Design Considerations for a Contactless Electric Vehicle Battery Charger.” *IEEE Transactions on Industrial Electronics* 52(5): 1308–14.
- Wang, Shuo, and David Dorrell. 2013. “Review of Wireless Charging Coupler for Electric Vehicles.”

- IECON Proceedings (Industrial Electronics Conference)*: 7274–79.
- Wang, Yijie, Yousu Yao, Xiaosheng Liu, and Danguo Xu. 2017. “S/CLC Compensation Topology Analysis and Circular Coil Design for Wireless Power Transfer.” *IEEE Transactions on Transportation Electrification* 3(2): 496–507.
- Wei Zhang, Student, Chunting Chris Mi, Fellow,. “Compensation Topologies of High-Power Wireless Power Transfer Systems. (2015). *IEEE Transactions on Vehicular Technology*, 65(6), 4768-4778.
- Xie, L., Shi, Y., Hou, Y. T., & Lou, A. (2013). Wireless power transfer and applications to sensor networks. *IEEE Wireless Communications*, 20(4), 140-145.
- Yang, Guang ., Song, K., Sun, Y., Huang, X., Li, J., Guo, Y., ... & Zhu, C. 2021. “Interoperability Improvement for Rectangular Pad and DD Pad of Wireless Electric Vehicle Charging System Based on Adaptive Position Adjustment.” *IEEE Transactions on Industry Applications* 57(3): 2613–24.
- Yilmaz, Murat, and Philip T. Krein. 2013. “Review of Battery Charger Topologies, Charging Power Levels, and Infrastructure for Plug-in Electric and Hybrid Vehicles.” *IEEE Transactions on Power Electronics* 28(5): 2151–69.
- Yu, Huiling, and Zhongwei Chen. 2021. “Laser Wireless Energy Supply System of High-Potential Monitoring Equipment Based on Machine Vision.” *Journal of Physics: Conference Series* 1820(1).
- Zaheer, Adeel, Hao Hao, Grant A. Covic, and Dariusz Kacprzak. 2015. “Investigation of Multiple Decoupled Coil Primary Pad Topologies in Lumped IPT Systems for Interoperable Electric Vehicle Charging.” *IEEE Transactions on Power Electronics* 30(4): 1937–55.
- Zamani, Mohammad, Mahmood Nagrial, Jamal Rizk, and Ali Hellany. 2019. “A Review of Inductive Power Transfer for Electric Vehicles.” *2019 International Conference on Electrical Engineering Research and Practice, iCEERP 2019*: 1–5.
- Zhang, Jin, and Chonghu Cheng. 2016. “Analysis and Optimization of Three-Resonator Wireless Power Transfer System for Predetermined-Goals Wireless Power Transmission.” *Energies* 9(4). doi: 10.3390/en9040274.
- Zhang, Wei, Jeff C. White, Arpith Mathew Abraham, and Chunting Chris Mi. 2015. “Loosely Coupled Transformer Structure and Interoperability Study for EV Wireless Charging Systems.” *IEEE Transactions on Power Electronics* 30(11): 6356–67.
- Zhang, Zhen, Hongliang Pang, Apostolos Georgiadis, and Carlo Cecati. 2019. “Wireless Power Transfer - An Overview.” *IEEE Transactions on Industrial Electronics* 66(2): 1044–58.
- Zhao, Lei, Duleepa J. Thrimawithana, and Udaya K. Madawala. 2017. “Hybrid Bidirectional Wireless EV Charging System Tolerant to Pad Misalignment.” *IEEE Transactions on Industrial Electronics* 64(9): 7079–86.
- Zheng, Cong et al. 2015. “High-Efficiency Contactless Power Transfer System for Electric Vehicle Battery Charging Application.” *IEEE Journal of Emerging and Selected Topics in*

*Power Electronics* 3(1): 65–74.

Zheng, Y. Dong, Y. Xu, K. Meng, J. H. Zhao, and J. Qiu. 2014. “Electric Vehicle Battery Charging/Swap Stations in Distribution Systems: Comparison Study and Optimal Planning.” *IEEE Transactions on Power Systems* 29(1): 221–29.

Zhong, Lingshu, and Mingyang Pei. 2020. “Optimal Design for a Shared Swap Charging System Considering the Electric Vehicle Battery Charging Rate.” *Energies* 13(5).

Zhu, Xirui, Jin, K., Hui, Q., Gong, W., & Mao, D. 2021. “Long-Range Wireless Microwave Power Transmission: A Review of Recent Progress.” *IEEE Journal of Emerging and Selected Topics in Power Electronics* 9(4): 4932–46.



**Hasan Y Mohammed** earned his B.Sc. in 2006 from the Technical Engineering College/Mosul, Northern Technical University, Iraq. he currently works as an engineer for the Ministry of health/Projects and Engineering Services department / Nineveh, Iraq. he can be contacted at email: [hasan.yousef@ntu.edu.iq](mailto:hasan.yousef@ntu.edu.iq)



**Ahmed J. Ali** is a lecturer at Dep. of power engineering technology/ Engineering Technical College/Mosul. He has get BSc and MSc. From University of Technology/ SBaghdad in 1995 and 2004 respectively in Electrical Engineering. He has finish his Ph.D. in Electrical Machines from

university of Mosul in 2012. He has been Bunsvuer University /Germany in Research Scholarship for 6 months during his Ph.D. studying period. His filed of work concentrate on Adaptive and Intelligent control Systems, Electric machines Design and Drives, wireless power transfer, FEA. Now he is Head Dep. of Power Engineering Technology at Engineering Technical College/Mosul:

[ahmed.j.ali@ntu.edu.iq](mailto:ahmed.j.ali@ntu.edu.iq)



**Assist. Prof. Dr. Rakan Khalil Antar** got his B.Sc., M.Sc. and Ph. D. degrees from University of Mosul, Iraq in 2002, 2005 and 2013 respectively. Now, he is a lecturer at Technical Engineering College, Northern Technical University, Iraq. He is concerned in power electronics, power quality, power converters and drives, and renewable energies.[rakan.antar@ntu.edu.iq](mailto:rakan.antar@ntu.edu.iq);